

Top

Large top lip allows or items to be clamped.

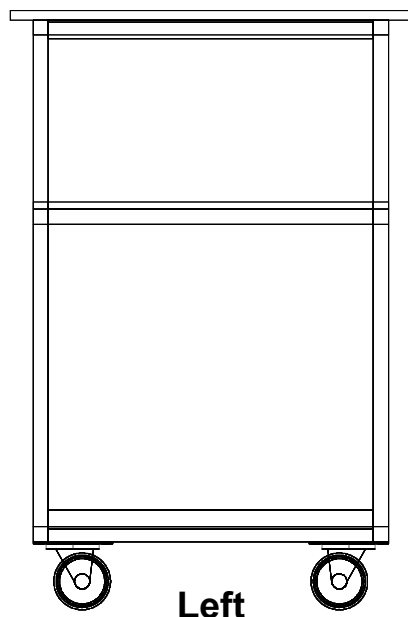

Left

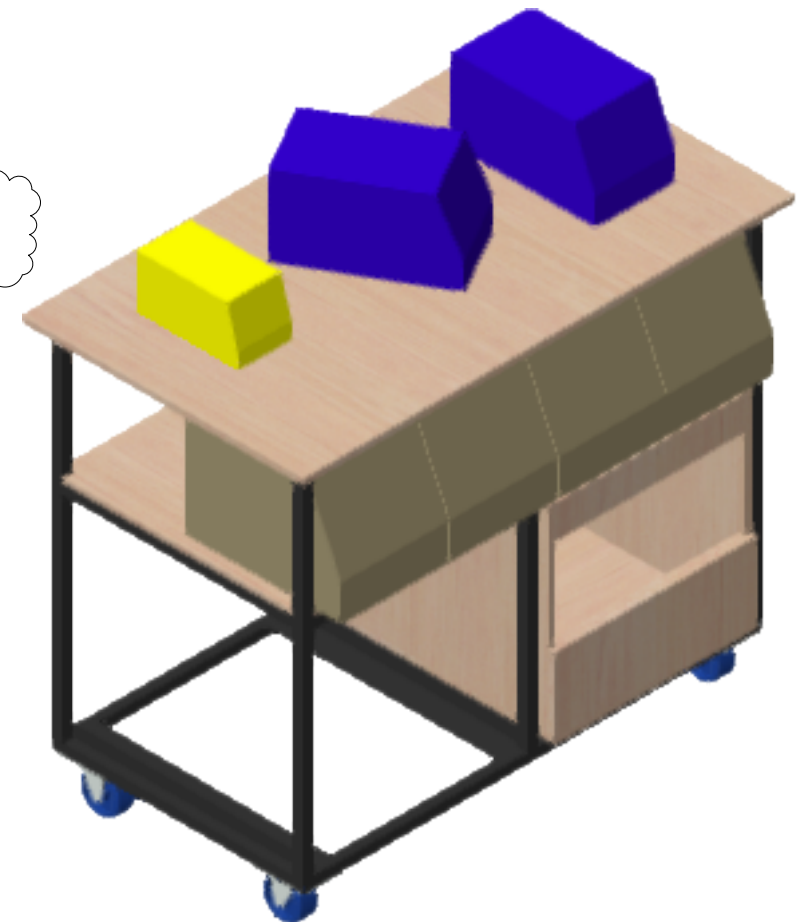
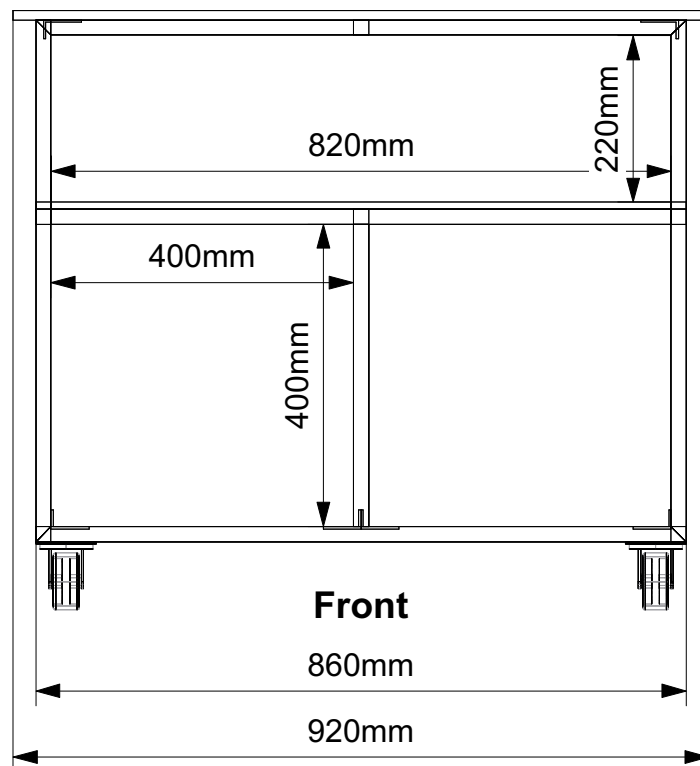

Front

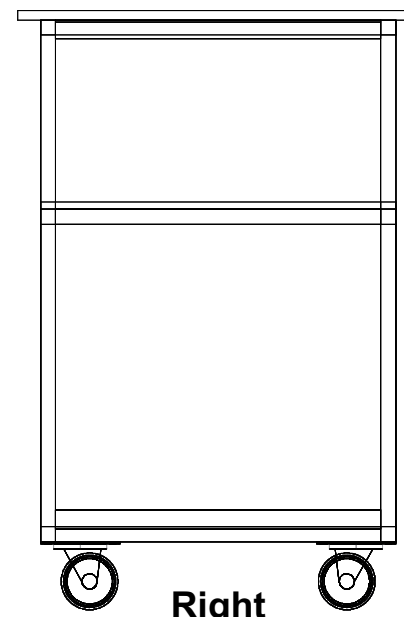

Right

General Notes

- The rolling storage allows for storage boxes to be transported easily from cage to stage if a large number of items are being used.
- On 4 swivel castors. 2 have locks to allow the top to be used as a portable work table onstage.
- Top sheeted with 12mm birch ply.
- Shelf sheeted with 9mm birch ply.
- Structure made of welded 20x20 ERW.
- Large boxes slide on 25x50 Angle welded to the frame.
- Top held on with 25x50 angle with screw holes. This allows it to be removed/replaced if necessary.

Sheeted top for storage and work table.

Top shelf for plastic storage box transportation.

Bottom holds 2 large storage boxes.

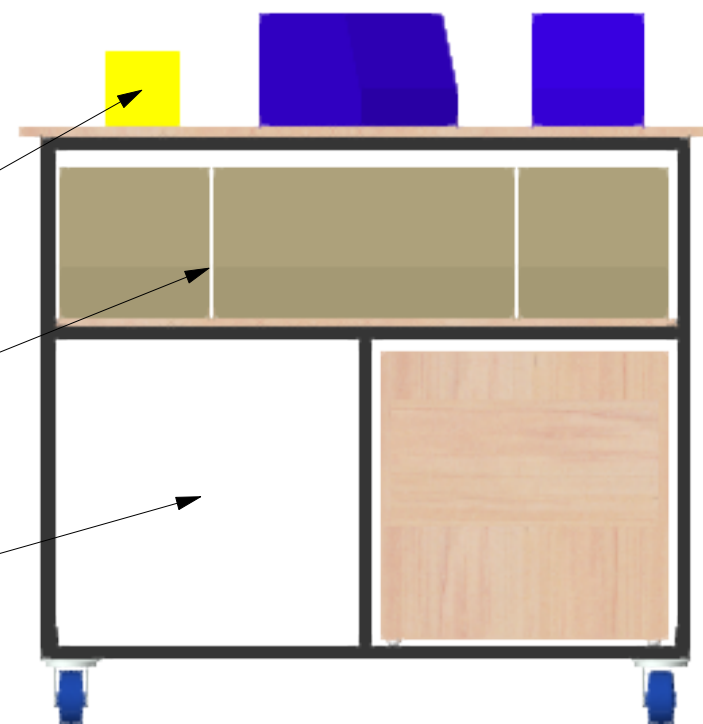

Title Rolling Storage - 1:10@A3		
Drawing Number 2	Drawn By YSW	Date 26/04/18
CAD File Name Cage 2018		