

Description	Specification
External dimensions (height x width)	292 mm x 260. mm
Distance between axis	239 mm
Lenghtways tubes	Extruded aluminium EN AW 6082 T6 - Ø49x3 mm
Crossways tubes	Extruded aluminium EN AW 6082 T6 - Ø20x2 mm
Connecting plate	Cast aluminium EN AC 42200 T6
Welding process	TIG -141 / ISO 4063
Available lenght (cm)	10.5 - 21 - 25 - 50 - 100 - 150 - 200 - 250 - 300 - 350 - 400
Connection systems	QXFC

Section Area [mm ²]	Moment of inertia Y - axis [mm ⁴]	Moment of inertia Z - axis [mm ⁴]	Selfweight (approx.) [N/m]		
1.272	10.647.580	10.645.580	60		

Span [m]	Centre Point Load (C.P.L.)			Third Point Load (T.P.L.)			Quarter Point Load (Q.P.L.)			Fifth Point Load (F.P.L.)			Uniformly Distributed Load (U.D.L.)		
	Point Load [kg]	Full Load [kg]	Central Deflection [mm]	Point Load [kg]	Full Load [kg]	Central Deflection [mm]	Point Load [kg]	Full Load [kg]	Central Deflection [mm]	Point Load [kg]	Full Load [kg]	Central Deflection [mm]	Load [kg/m]	Full Load [kg]	Central Deflection [mm]
2	1093	1093	2	820	1639	3	547	1640	2	455	1822	3	1070	2141	3
3	725	725	5	544	1087	6	362	1087	6	302	1208	6	483	1450	6
4	540	540	8	405	809	11	270	809	10	225	899	10	270	1079	10
5	427	427	13	321	641	17	214	641	15	178	712	16	171	855	16
6	352	352	19	264	528	24	176	528	22	147	586	24	117	704	23
7	297	297	26	223	446	32	149	446	30	124	496	32	85	595	32
8	256	256	34	192	384	42	128	384	40	107	426	42	64	511	42
9	223	223	43	167	334	54	111	334	50	93	372	53	50	446	53
10	196	196	54	147	294	67	98	294	62	82	327	66	39	392	65
11	174	174	66	130	261	81	87	261	76	72	290	80	32	348	79
12	155	155	79	116	232	96	77	232	90	65	258	95	26	310	94
13	139	139	93	104	208	113	69	208	107	58	231	112	21	277	111
14	124	124	109	93	186	131	62	186	124	52	207	130	18	248	129
15	111	111	127	83	167	151	56	167	143	46	186	150	15	222	149
16	100	100	146	75	150	173	50	150	164	39	166	171	13	200	170

Load table has been prepared in accordance with UNI ENV 1999-1-1 (Eurocode 9).
 When calculating the allowable loads shown in the table, it is assumed that the trusses are simply supported at the end connection and that static loads will be applied to the node points.
 The application of the load shall be on the centre line of the truss.
 The values shown in the table are the allowable statics loads that can be applied to the truss. This is the live load or the payload.
 The self weight of the truss has been taken into account when calculating the values in the table.
 It should be noted that this is idealised loading condition and the User shall re-analyze the truss for the loading condition which prevail for the application begin considered.

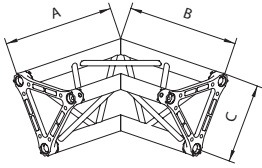

TH30SAL2090

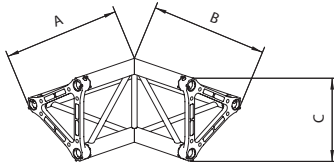

TH30SAL2090E

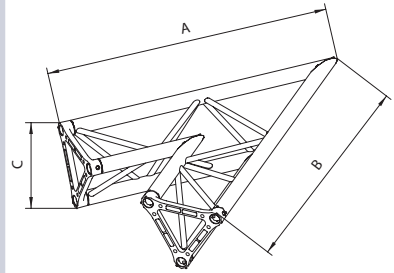

TH30SAL2045

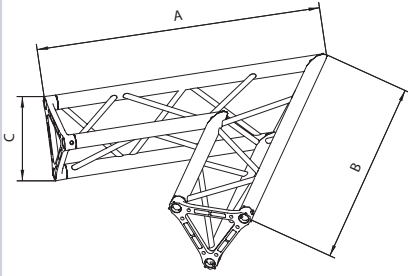

TH30SAL2060

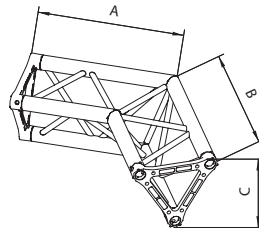

TH30SAL2120

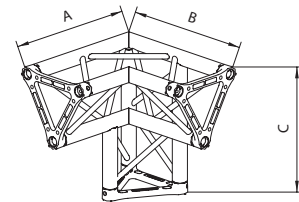

TH30SAL3L

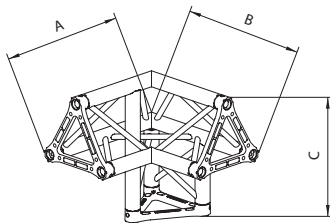

TH30SA3LU

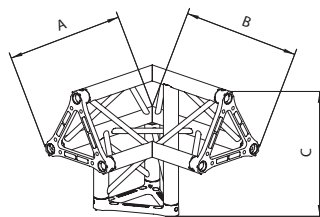

TH30SAL3RU

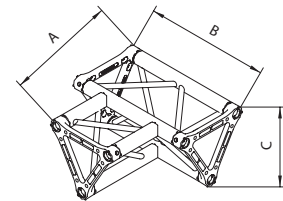

TH30SAT3

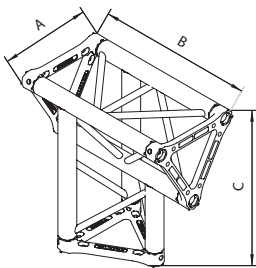

TH30SAT3F

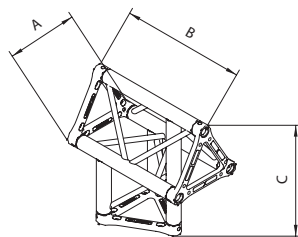

TH30SAT3FU

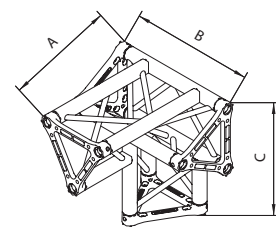

TH30SAT4

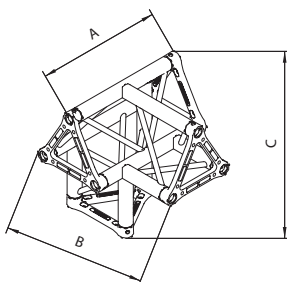

TH30SAT4FU

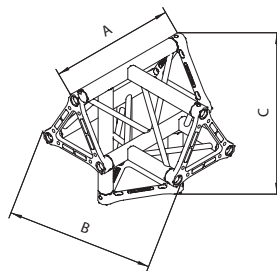

TH30SAT4LU

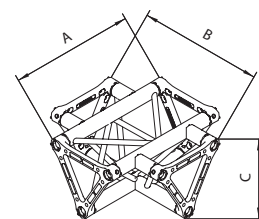

TH30SAX4

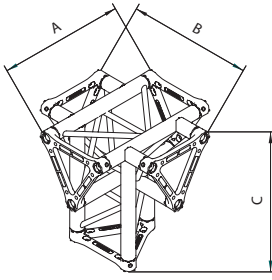

TH30SAX5

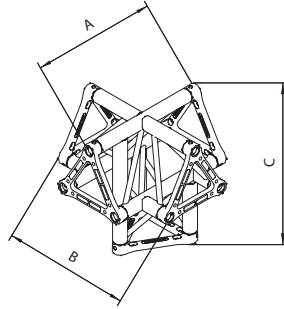

TH30SA5NU

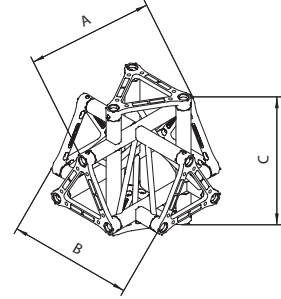

TH30SAX6

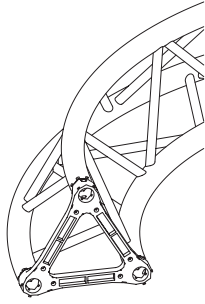

T = VERTEX ON TOP

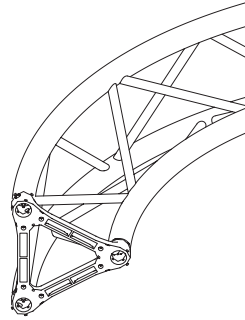

TI = INTERNAL VERTEX

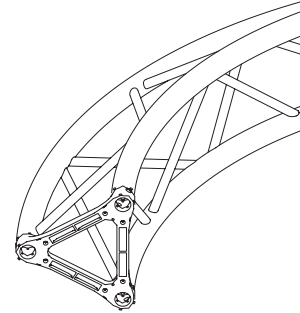

TE = EXTERNAL VERTEX